

VOLUME	PRODUCTS CATALOGUE
<b>02</b>	<b>POST TENSIONING</b>

YOUR CHALLENGES,  
OUR SOLUTIONS





---

<b>01. COMPANY PROFILE .....</b>	<b>03</b>
<b>02. STRAND POST TENSIONING SYSTEMS.....</b>	<b>07</b>
<b>03. BAR POST TENSIONING SYSTEMS.....</b>	<b>21</b>
<b>04. SYSTEM PROPERTIES AND DIMENSIONS.....</b>	<b>25</b>
<b>05. INSTALLATION .....</b>	<b>33</b>
<b>06. INSTALLATION EQUIPMENT .....</b>	<b>37</b>
<b>07. EQUIPMENT PROPERTIES AND DIMENSIONS.....</b>	<b>41</b>



---

High Speed Train line from Milan to Naples, Piacenza viaduct, Piacenza (Italy)

---

# 01

---

## COMPANY PROFILE

Our mission is to constantly improve the methods  
and the quality of construction processes  
through research, innovation and cooperation  
with designers, engineers and contractors worldwide.



# TENSA

---

Tensacciai, now renamed TENSA, was founded in 1951 with headquarters in Milan, Italy. It is now active in over 50 countries with a direct presence in 14 countries. TENSA is a leader in stay cables, post-tensioning, anti-seismic devices, structural bearings and expansion joints. TENSA has extensive references and numerous certifications for its products worldwide.

## HISTORY

**1951:** Beginning of activity

**1964:** In the sixties Tensacciai undergoes a phase of remarkable growth in Italy. Post-tensioning is just at the beginning of its history and its application is still experimental.

**1970:** A programme of technological renewal begins with the adoption of the steel strand.

**1980:** Tensacciai develops new tensioning systems and equipment in the field of ground anchors, combining innovation with versatility and ease of use.

**1990:** New subsidiaries established in Brazil, India and Australia and in Europe sister companies in Portugal, Greece and the Netherlands.

**2000:** The internationalization process of Tensacciai continues unabated.

**2010:** The company becomes directly involved in projects in all five continents.

**2011:** Tensacciai is acquired by Deal - world leading solutions provider in the field of bridge construction - and becomes part of De Eccher Group. Tensacciai is now member of an organisation capable of designing, manufacturing and installing systems everywhere in the world, thanks to specialised technicians, engineers in the technical department and quality control. All production and delivery processes are attested by the ISO9001 certification.

**2012:** Tensacciai merges with Tesit, another successful concrete specialist contractor with international experience in post-tensioning, steel bars, structural bearings and expansion joints becoming a prominent player in the field of specialised subcontracting.

Tensacciai enters into a Worldwide Exclusive License Agreement with Rome-based TIS (Tecniche Idraulico-Stradali S.r.l.) - a leading company with experience in designing and producing structural bearings, expansion joints and anti-seismic devices since 1973.

**2014:** TIS is acquired by Tensacciai.

**2015:** TENSA is formed from the merging and development of the three important companies mentioned above: Tensacciai, Tesit, TIS.

After the successful completion of the Manhattan west project and the implementation of the Tensa stay cable system in the Pearl Harbor memorial bridge in New Haven, CT, Tensa America was established with main office in Miami, FL.

## MISSION

Our mission is to constantly improve the methods and the quality of construction processes through research, innovation and cooperation with designers, engineers and contractors worldwide. A strong commitment to quality is the only way to ensure safe and long-lasting structures. We support the design from the initial stage, challenging standards to develop custom solutions. We value timely execution and service as keys to building long-term relationships.

Our core knowledge lies within stay-cables and post-tensioning systems, anti-seismic devices, structural bearings and expansion joints as well as all the related accessories, equipment and services.

TENSA strives to push its vast experience towards new methods and variations of applications, developing ingenious solutions for building new structures, whether they are buildings or infrastructures, as well as the rehabilitation of existing ones.

## PRODUCT CATALOGUES

01 - STAY CABLES

**02 - POST TENSIONING**

03 - GROUND ANCHORS

04 - EXPANSION JOINTS

05 - BEARINGS

06 - DAMPERS & STUs

07 - SEISMIC ISOLATORS

08 - ELASTO PLASTIC DEVICES

09 - VIBRATION CONTROL

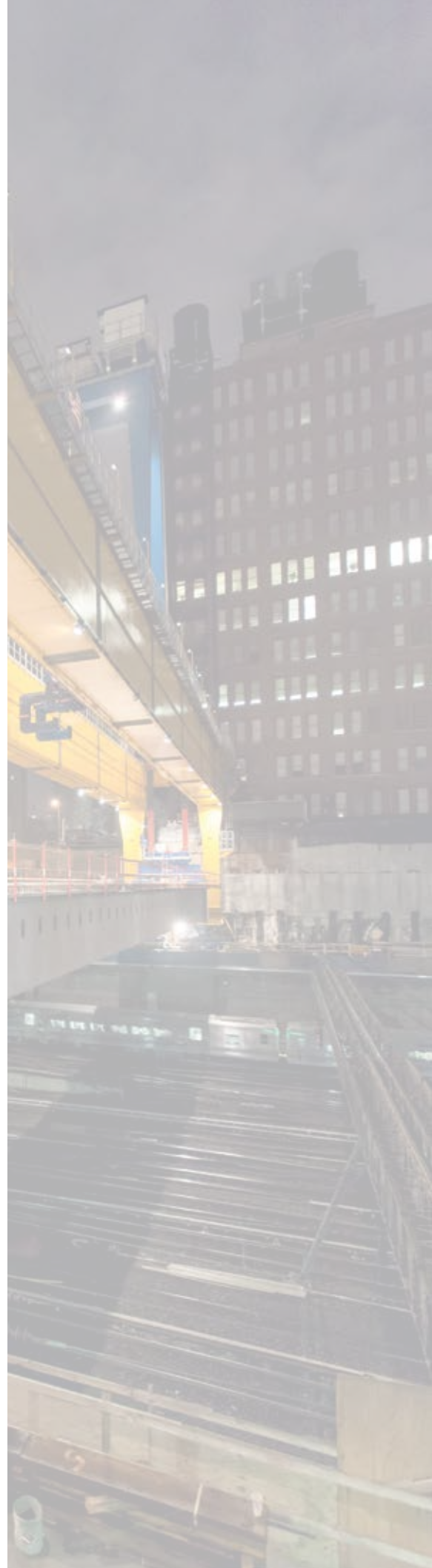

Highway viaduct, Loureiro (Portugal)





---

# 02

---

## STRAND POST TENSIONING SYSTEMS

The post-tensioning system is suitable for concrete, composite and steel structures. A wide range of different systems is available.

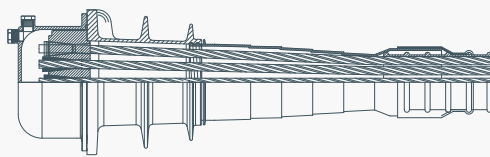

# GENERAL OVERVIEW

---

Post tensioning is a highly efficient structural reinforcement system that offers many benefits in a wide range of construction, repair and rehabilitation applications.

It can be applied in all types of construction, which include, without limitation, general buildings, special slabs, bridge decks, storage tanks, pavements and other geotechnical applications.

Compression stresses to concrete can be applied with the use of post tensioning tendons made of steel strands or steel bars.

When such tendons are fully installed in ducts within the concrete, post tensioning systems are defined as internal.

If the main tensile elements are in full adherence with the structure, the systems are defined as bonded, while they are unbonded in the other case.

In the event that the tendons are placed in ducts outside the concrete structure, such post tensioning systems are referred to as external.

Tendons are usually made of several strands (multi-strand systems), but mono-strand systems are also widely used.

High Speed Train line from Milan to Naples, Piacenza viaduct, Piacenza (Italy)



A post tensioning system employing strands is usually composed of:

## PROPRIETARY COMPONENTS

**Wedge:** device capable of gripping the single strand and transferring the load to the anchor plate through the conical hole in it.

**Wedge plate:** steel disk hosting strands and wedges, resting over the cast-iron block embedded into the concrete.

**Cast-iron block:** piece designed to transfer the load to the surrounding concrete. In some systems it can also be designed to directly accommodate holes for wedges that grip the strand.

**Deviation rear trumpet:** when present, it is joined to the cast-iron block and permits the deviation of the entire bundle of strands entering the duct.

**Confinement and Bursting reinforcement:** spiral-shaped reinforcement and rebars properly placed around the anchorage to ensure the bearing of local high stresses and the containment of local tension-induced bursts.

**Permanent protection cap:** made of fiber reinforced plastic, it is used to cover the entire anchor plate and protect it from external agents.

## STANDARD COMPONENTS

**Seven wire steel strand:** main tensile element transmitting the load through the entire tendon.

**Ducts:** they create void conduits where the bundle of strands is threaded.

**Grout:** a mix of water and cement-like materials required to fill the voids within the duct, providing protection and full bonding.

**Corrosion protection injection compounds:** materials used to protect the main tensile elements and the anchorages as a better performing alternative to simple grouting. They are usually called "flexible fillers".

# QUALITY AND CERTIFICATIONS

Post tensioning systems have been stringently tested under the requirements of AASHTO LRFD Specifications, PTI/ASBI M50 "Guide Specification for grouted post-tensioning" and State DOTs Specifications.

Tests have been performed in AASHTO qualified laboratories in full compliance with Technical Specifications.

TENSA AMERICA is member of Post-Tensioning Institute (PTI) and active part in Technical Committees.

Post-tensioning systems have also been tested as per European Technical Approval guideline ETAG013 and consequently granted European Technical Assessment 08/0012, 11/0007 and 15/0023.

Systems are also provided with relevant Declarations of Performance (CE marking).

As a specialized contractor with decades of experience in its specific field, TENSA does not only provide supply and installation services of the finished products, but it is also capable of providing a wide range of associated services, starting with the design, moving on to the assembly and laboratory testing, including the definition of operating manuals and installation procedures, and ending with the provision of all engineering services related to the installation and maintenance throughout the life of the post-tensioned works. All this is carried out by TENSA's own teams of specialised and highly experienced technicians under a system that promotes full accountability and is in compliance with the standards of ISO9001.

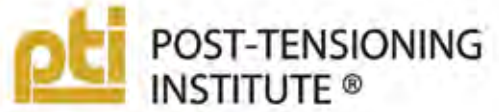

# SYSTEM COMPONENTS

## STEEL STRAND

Post tensioning tendons are usually made of strands 0.6'' (15.2mm) diameter. System is also available for 0.62'' (15.7mm) and 0.5'' (12.7mm).

Dimensions and properties of 7-wire strands according to ASTM A416/A416M

Grade - Tensile strength	[ksi]	270	270	270
	[MPa]	1860	1860	1860
Diameter	[in.]	0.6	0.62	0.5
	[mm]	15.2	15.7	12.7
Steel Area of Strand	[in. <sup>2</sup> ]	0.217	0.231	0.153
	[mm <sup>2</sup> ]	140	150	98.7
Mass of Strand	[lb/1000ft]	740	780	520
	[g/m]	1100	1200	780
Permissible variations in Diameter	[in.]	+0.026/-0.006	+0.026/-0.006	+0.026/-0.006
	[mm]	+0.65/-0.15	+0.65/-0.15	+0.65/-0.15
Minimum Breaking Strength of Strand	[kips]	58.6	62.8	41.3
	[kN]	261	279	184
Initial Load	[kips]	5.86	6.28	4.13
	[kN]	26.1	27.9	18.4
Minimum elongation	[%]	3.5	3.5	3.5
Relaxation after 1000 hours at 70% of minimum breaking strength	[%]	2.5	2.5	2.5

## DUCTS

Depending on protection level classes required for the project, ducts for internal bonded PT, can be made of plastic material or galvanized steel sheaths.

Typically, as per PTI/ASBI M50, protection level class PL1 requires galvanized metal ducts while classes PL2 and PL3 are associated with plastic ducts.

They have a corrugated outside surface that guarantees the best possible adherence with the enveloping concrete.

In the case of the plastic ducts, the thickness varies from 0.098" to 0.157".

Dimensions used have to be in compliance with AASHTO requirements and in accordance with operating conditions.

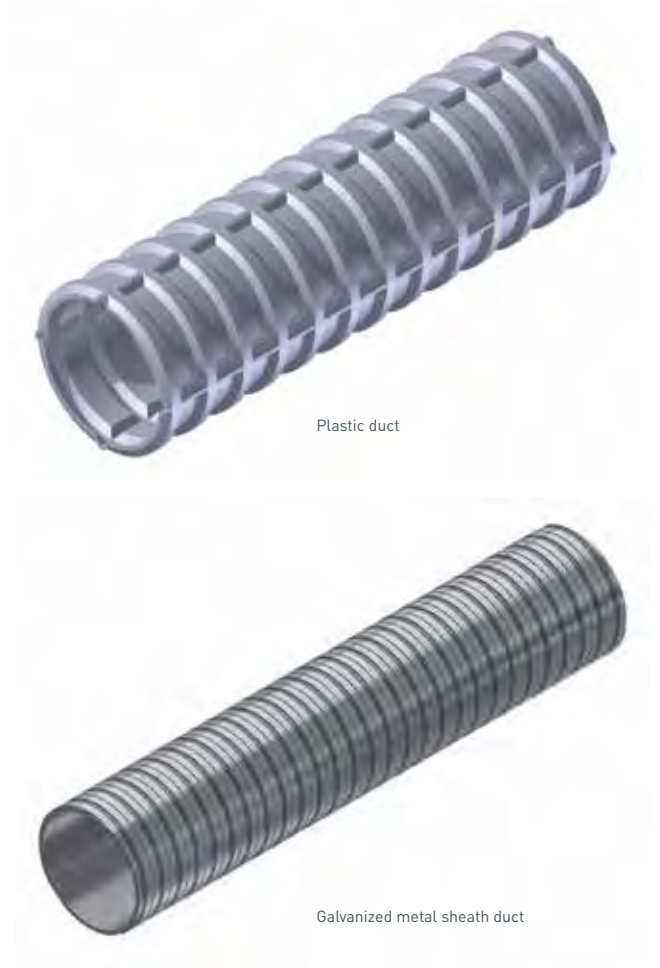

### Suggested technical data

STRAND NO.		7	9	12	15	19	22	27	31	37
Internal $\Phi$	[in.]	2.32	2.99	2.99	3.35	3.94	4.53	4.53	5.12	5.12
	[mm]	59	76	76	85	100	115	115	130	130
Grout requirement	[gal/ft]	0.14	0.26	0.23	0.29	0.42	0.59	0.53	0.72	0.65
	[l/m]	1.8	3.3	2.9	3.6	5.2	7.3	6.6	9.0	8.1

# MULTI STRAND POST TENSIONING SYSTEMS

---

Multi-strands systems are provided with a wide range of anchorages and solutions for different construction needs.

They can be used in concrete and composite structures, both for new constructions and the rehabilitation of existing structures where an increase in resistance is required.

## INTERNAL BONDED AMTS ANCHORAGE

The live anchorage AMTS has been designed and tested to meet the performance and corrosion protection requirements set in PTI/ASBI M50 Guide Specification for grouted post-tensioning.

It offers a wide range of sizes and a complete set of dedicated accessories to allow complete and satisfactory installation. Standard product layout is designed in order to meet protection level class PL-2 as per PTI/ASBI M50 and FIB Bulletin 33 Recommendation.

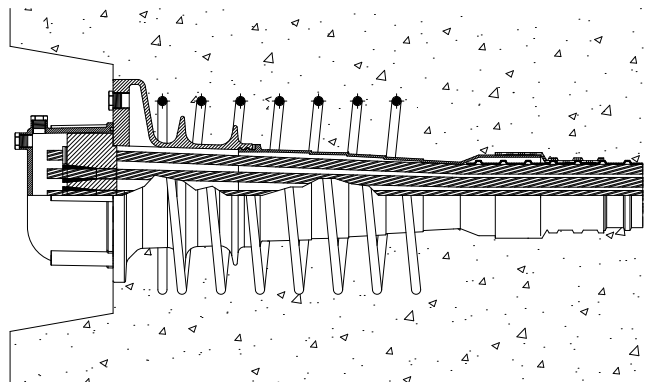

## INTERNAL FLAT BONDED APTS

The live flat anchorage APTS with its compact geometry is suitable for use in thin slabs and for decks' transversal post-tensioning.

It is in full compliance with performance and corrosion protection requirements set in PTI/ASBI M50 Guide Specification for grouted post-tensioning.

Standard product layout is designed in order to meet protection level class PL-2 as per PTI/ASBI M50 and FIB Bulletin 33 Recommendation.

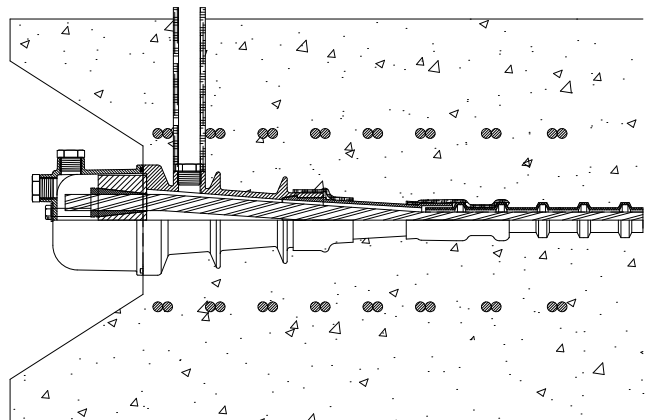

## MTAID ELECTRICALLY INSULATED ANCHORAGE

MTAID anchorage for electrically insulated post tensioning is designed to meet the demand for a total and permanent protection of post tensioning tendons from corrosive agents. This protection is granted by the tendon's complete envelopment, which is made of:

- MTAID anchorage with anchor plate separated from the cast-iron block by means of rigid dielectric disks, plastic connectors positioned inside the cast-iron block and connected to the corrugated ducts by means of tight joint seals
- full covering plastic protection cap
- plastic ducts in the free length

The electrically insulated post tensioning system offers measurable advantages:

- electrical insulation of the cable from the surrounding environment and consequent protection against corrosion caused by electrochemical phenomena, oxidation and chlorides attack;
- possibility of controlling the protection's integrity through electrical resistance measures during the structures's life-time.

This system has been widely used and tested in the world's largest full scale application of its kind, the 4.3 km long Piacenza viaduct (Italy).

This system is in compliance with class PL-3 requirements of PTI/ASBI M50 "Guide Specification for Grouted Post-tensioning".

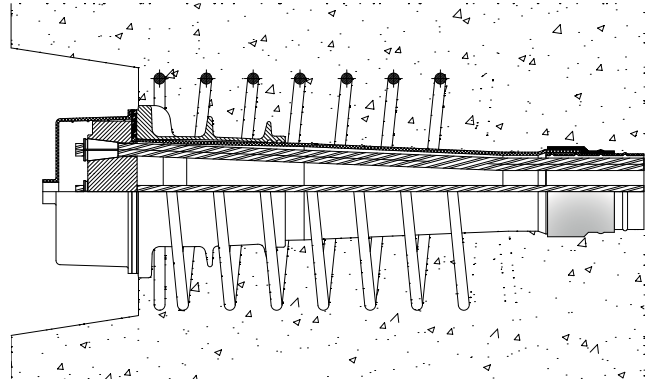

High Speed Train line from Milan to Naples,  
Piacenza viaduct, Piacenza (Italy)



## EXTERNAL AMTS ANCHORAGE

The live anchorage AMTS external allows the installation of a complete external tendon meeting requirements set in PTI/ASBI M50 Guide Specification for grouted post-tensioning. It offers a wide range of sizes and a complete set of dedicated accessories to allow complete and satisfactory installation.

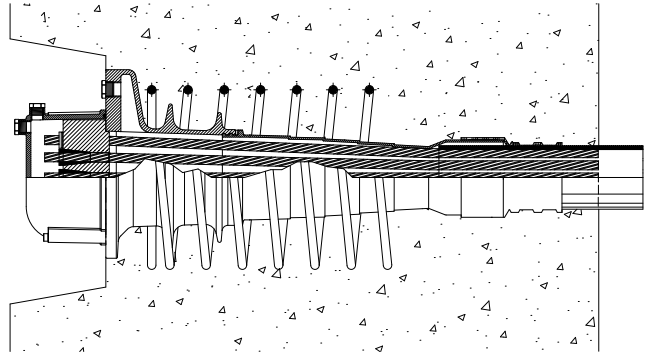

Full scale pressure tests





## INTERNAL MTAI LIVE ANCHORAGE

The live anchorage MTAI is the most used and widely spread type of anchorage, whose compact geometry and reduced deviation angle provides a competitive advantage in all project applications, combined with high performance standards and ease of installation. It can be also used in the unbonded MTAIU version, where single sheathed strands are used.

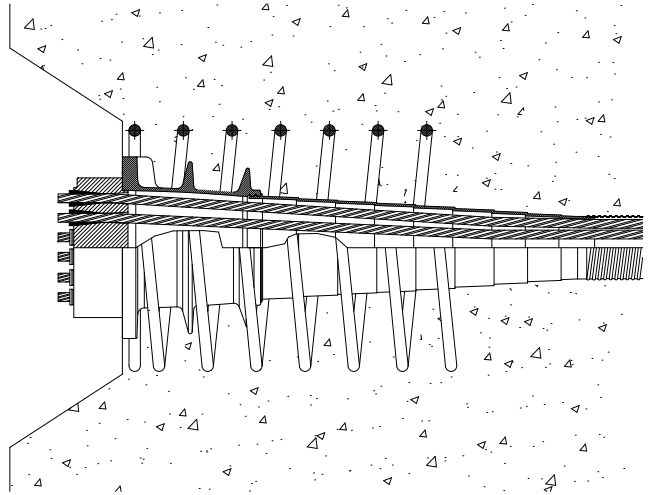

## MTAI SYSTEM IN CRYOGENIC APPLICATIONS

System has been successfully tested at cryogenic conditions as per ETAG013 and SR 88/2. Compliance for use in LNG tanks and special structures has been completely assessed by Third Party Laboratories.



## INTERNAL MTAIM DEAD ANCHORAGE

It is a non-accessible (dead) anchorage which is used in case accessibility during the stressing phases is not allowed. In such a case strands are placed before pouring the concrete of the structure.

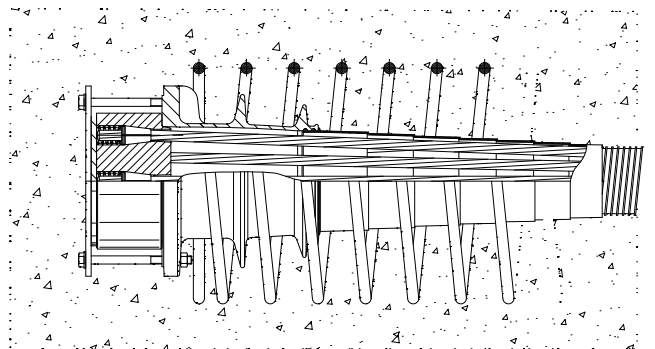

## MTG COUPLER ANCHORAGE

MTG system is the type of anchorage suitable for the coupling of tendons.

It is fully integrated with the MTAI system and allows installation of a secondary tendon after the primary one has been completely installed.

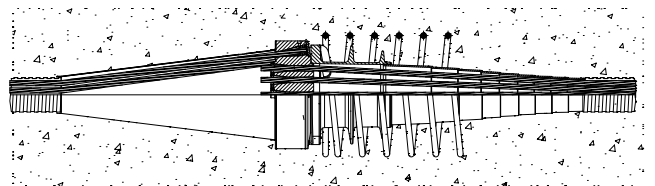

## EXTERNAL MTAIE ANCHORAGE

This anchorage can be used in external tendons and comes in different versions, such as:

- fully dismantlable (MTAIE), through the presence of an inner steel cone that separates strands and inner protective injection from the surrounding elements in the anchorage zone;
- restressable (MTAIER) by means of a special long protection cap and the use of greased and coated strands;
- not exchangeable (MTAIEEX).

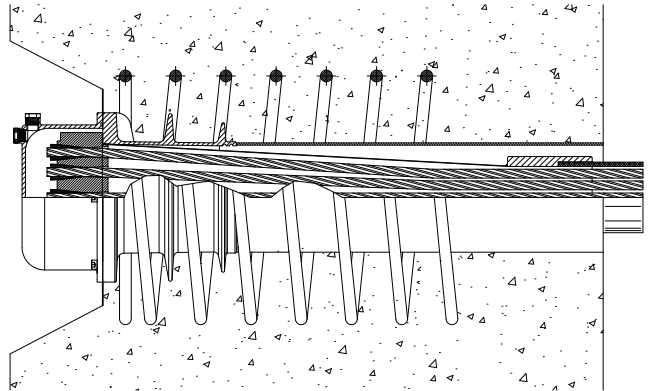

## CU COUPLING SYSTEM

Single strand CU couplers are used to connect tendons built in different stages. Connection is made with single strand CU couplers, to be placed in different layers enabling a compact shape.

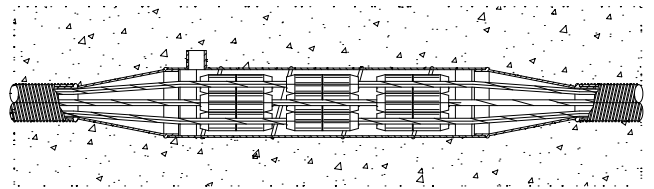

## DF ANNULAR ANCHORAGE

Special rectangular anchorages are used for ring and intermediate post tensioning: these anchorages also use a special deviator for tensioning with mono-strand jacks.

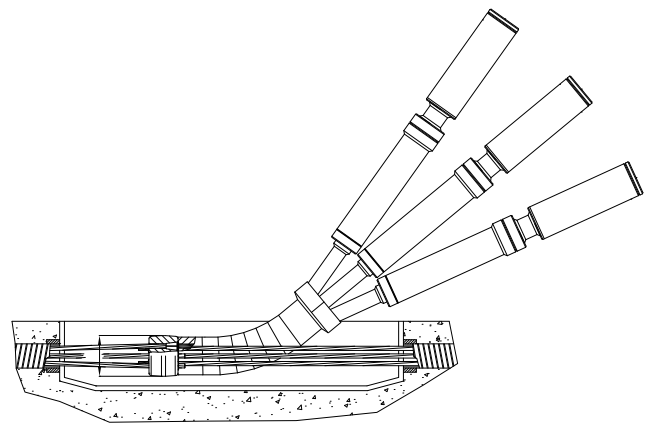

## ST ANCHORAGE

It is used as a dead end anchorage, done by creating a bulb end on each of the strands composing the tendon.

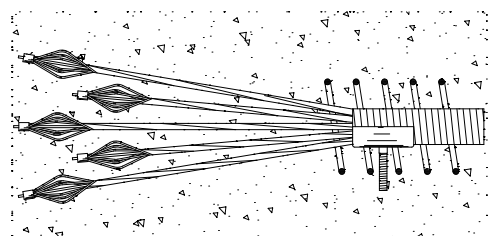

# MONO STRAND POST TENSIONING SYSTEMS

Mono-strand systems are used for post tensioning of concrete slabs, pavements, separation walls and special concrete structures such as underground car parks, silos and tanks.

They can be used for unbonded or bonded applications.

The most widely-used is the unbonded application, where the use of greased and coated strands allows fast installation of mono-strand tendons without duct placing and absence of bond between plastic coating and concrete.

In such a case, the main advantages are:

- strands are covered with special corrosion inhibitor grease and with a proof PE coating;
- high performance in service conditions (SLS);
- possibility to maximize cables' eccentricity;
- rapidity of installation;
- reduction of cracking phenomena.



Isozaki Tower, Milan (Italy)

## Suggested technical data

Diameter	[in.]	0.6	0.62
	[mm]	15.2	15.7
Grade - Ultimate strength	[ksi]	270	270
	[Mpa]	1860	1860
Area	[in. <sup>2</sup> ]	0.217	0.231
	[mm <sup>2</sup> ]	139	150
Maximum load	[kips]	58.6	62.8
	[kN]	259	279

In the case of bonded solutions, it is required to place corrugated metal sheaths or plastic ducts before concreting the structure and thread steel strands at the time of stressing. Grout injection is then necessary to complete corrosion protection and guarantee the bond between the tensile elements and the surrounding duct and concrete.



Regione Piemonte Tower, Turin (Italy)

### LIVE END TESIT 1C15 UL/BL

This anchorage is made of a single cast-iron piece which transfers the load from the tensile element to the concrete and hosts the wedge that grips the strand.

It is available either in the unbonded version 1C15UL or in the bonded 1C15BL, both complete with covering caps.

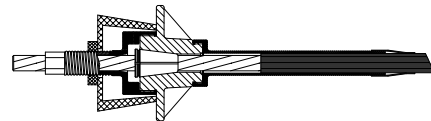

### DEAD END TESIT 1C15 UD/BD

It is used where anchorage is not accessible for stressing operations.

It can be provided both in the unbonded version 1C15UD or in the bonded 1C15BD version, complete with their relevant wedge spring and fixing cap.

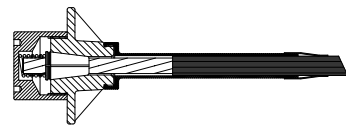

### COUPLER TESIT 1C15 UC/BC

This system allows direct mechanical coupling of tendons that have been placed during different construction phases.

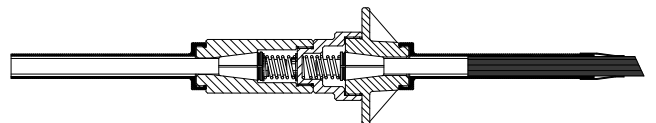





---

# 03

---

## BAR POST TENSIONING SYSTEMS

Threaded steel bars can be used in different applications and structures, providing safe and reliable application of post tensioning.

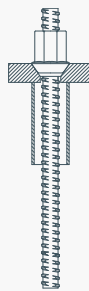

# BAR POST TENSIONING SYSTEMS

---

TENSA AMERICA supplies bars with continuous thread for post tensioning applications in buildings, roads, bridges and viaducts, tunnels and mine shafts.

These systems can be provided in diameters varying from 26 to 75 mm, and are used worldwide in post tensioning and in pre-tensioning systems applications.

The advantages of using these post tensioning systems are several and are supported by excellent results achieved on various project sites.

Different corrosion protection systems and steel grades are available.

## The main advantages are:

- Easy handling on-site;
- Continuous thread along the entire length of the bar, which ensures optimal adhesion to the cast in situ concrete;
- Cut to size and possibility of extension using couplers in any position of the bar;

- Different possibilities for protection against corrosive phenomena: galvanized, hot dip galvanized, epoxy coated, painted in accordance to different standards .

For special applications further steel grades are available.

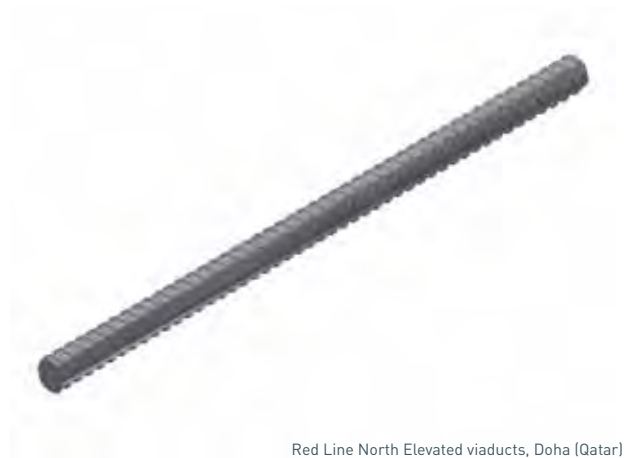

Red Line North Elevated viaducts, Doha (Qatar)





# STEEL BAR CHARACTERISTICS

CONTINUOUS LEFT OR RIGHT HAND, THREADED BAR, COLD ROLLED

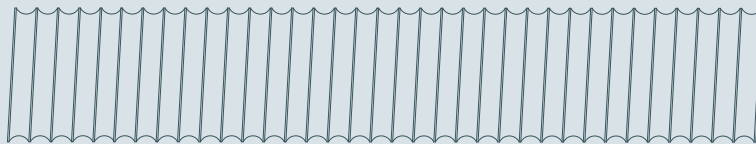
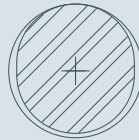

## R71 150 KSI ALL-THREAD-BAR

		[in.]	1"-4	1-1/4" - 4	1-3/8" - 4	1-3/4" - 3-1/2"	2-1/4" - 3-1/2"	2-1/2" - 3	3" - 3
Nominal bar diameter & Pitch	[mm]		26	32	36	46	57	65	75
	[in. <sup>2</sup> ]		0.85	1.25	1.58	2.6	4.08	5.19	6.46
Minimum net area	[mm <sup>2</sup> ]		549	807	1019	1664	2632	3350	4169
	[kips]		128	188	237	390	613	778	969
Minimum ultimate strength	[kN]		567	834	1054	1734	2727	3457	4311
	[kips]		102	150	190	312	490	622	775
Prestressing force 0,80f pu	[kN]		454	667	843	1388	2181	2766	3448
	[kips]		89.3	131	166	273	429	545	678
Prestressing force 0,70f pu	[kN]		397	584	738	1214	1909	2422	3018
	[kips]		76.5	113	142	234	368	467	581
Prestressing force 0,60f pu	[kN]		340	500	633	1041	1636	2074	2587
	[lbs./ft]		3.09	4.51	5.71	9.06	14.1	18.2	22.3
Nominal weight	[kg/m]		4.6	6.71	8.5	13.5	20.8	27.1	32.7
	[in.]		1-1/8"	1-7/16"	1-9/16"	2"	2-1/2"	2-3/4"	3-3/64"
Approx. Thread major diameter	[mm]		28.6	36.5	39.7	50.8	63.5	69.9	77.4

Several types of accessories are available to meet all design requirements. Full range of couplers, nuts and anchor plates, including special pieces can be provided on request. TENSA AMERICA is able to provide a wide range of product customization, for applications requiring new and different

shapes. End caps are always placed when it is necessary to provide a protective injection in the anchorage zone.

Bars can be provided with different corrosion protections such as spray galvanization, hot galvanization or epoxy coating.

